

TETRA MXM600 / M6



Motorola Digitalfunk Einbaugerät mit
Display-Lautsprecher-Bedienmikrofon



TETRA-FAHRZEUGFUNKGERÄT MIT DISPLAY-LAUTSPRECHER BEDIENMIKROFON MXM600 / M6

Das MXM600 bietet die Möglichkeit über ein **M6-Display-Lautsprecher-Bedienmikrofon** die Bedienung auch in sehr engen Fahrzeugen zu ermöglichen. Externe Lautsprecher oder Mikrofone können entfallen, welches den Installationsaufwand reduziert.

M6 Display-Lautsprecher-Bedienmikrofon:

Das M6 Display-Lautsprecher-Bedienmikrofon hat die Form eines tragbaren Funkgeräts, sodass alle MXM600-Tasten und Schalter in einer Hand gehalten werden können. Der T-Bar-Griff erleichtert die Handhabung und Bedienung, selbst mit Handschuhen. Mit einem integrierten Lautsprecher und Mikrofon auf der Vorderseite sowie zwei Lautstärkeoptionen für hohe und niedrige Lautstärke unterstützt das M6 sowohl normale PTT-Gespräche wie auch Vollduplex-Gespräche im Telefonmodus.

Das 2,4-Zoll-Display lässt sich je nach Befestigung vertikal oder horizontal ausrichten. Die Displayhelligkeit passt sich automatisch an das Umgebungslicht an. Zusätzlich besteht auch die Möglichkeit einer Nachtansicht, wozu das Display auf eine geringe Intensität eingestellt wird.

Mit der Schutzart IP56 ist das M6-Display-Lautsprecher-Bedienmikrofon robust und wetterbeständig konstruiert, um in allen gängigen Einsatzfahrzeugen installiert werden zu können.



TETRA-FAHRZEUGFUNKGERÄTE

SERIE MXM600 / M6



Für die Kommunikation ist eine klare Sprachkommunikation unverzichtbar.

Dank der integrierten KI-gestützten Technologie zur Unterdrückung störender Hintergrundgeräusche sorgt das MXM600 für eine bessere Verständlichkeit bei der Sprachübertragung. So können Ihre Einsatzkräfte auch in lauten Umgebungen klar und deutlich miteinander kommunizieren.

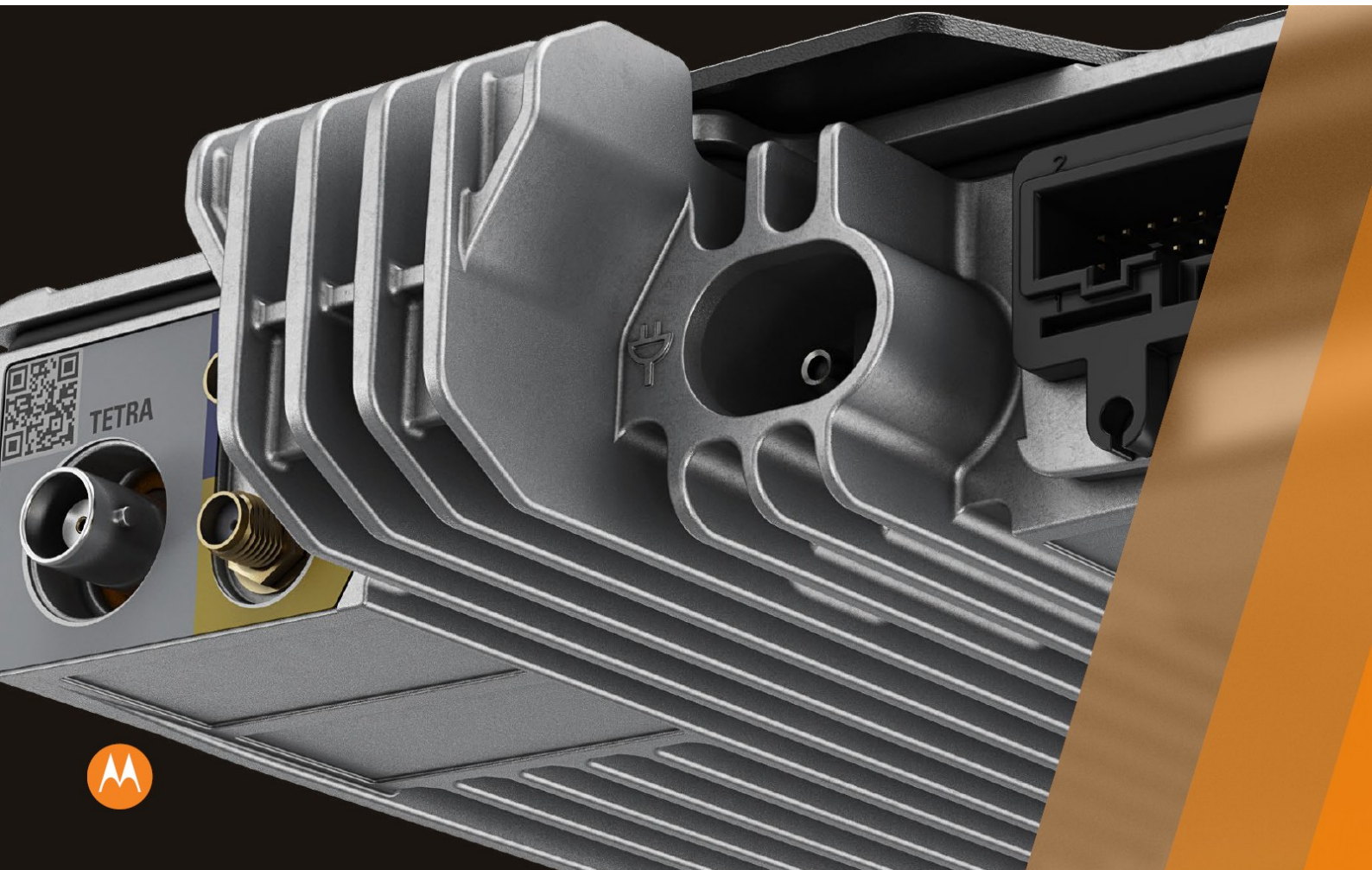

TETRA-FAHRZEUGFUNKGERÄTE

SERIE MXM600

Das MXM600 bietet eine zuverlässige TETRA-Funkversorgung und Abdeckung für die Sprach- und Datenkommunikation in Fahrzeugen und ermöglicht eine erweiterte Netzabdeckung für TETRA Handsprechgeräte.

TMO Netzversorgung:

Die externe Dachantenne eines MXM600 sorgt für eine hohe Empfangsempfindlichkeit und unterstützt eine höhere Sendeleistung als ein Handgerät. Mit einer Sendeleistung von 10 Watt (TETRA Leistungsklasse 2) bietet es eine höhere Reichweite als ein Funkgerät der Klasse 3 oder 4. So könnten Ihre Einsatzkräfte auch in Gebieten mit schlechterer Netzabdeckung in Kontakt bleiben, SDS-Kurznachrichten, Callout-Alarme empfangen und bestätigen und Notrufe absetzen. Dank der Gateway Funktion kann die Netzerweiterung auf nahegelegene TETRA-Handsprechfunkgeräte ausgedehnt werden, damit Ihre Teams immer in Verbindung bleiben.

TMO/DMO Gateway:

Im Gateway-Modus fungiert das MXM600 als Brücke zwischen dem TETRA-Netz und den TETRA-Handfunkgeräten, die sich außerhalb der Netzabdeckung befinden. Somit kann die Digitalfunkkommunikation aufrecht erhalten werden, wenn Einsatzkräfte beispielsweise ein Gebäude mit sehr guter Abschirmung betreten.

Durch das Aktivieren des TMO/DMO Gateways im Fahrzeugfunkgerät MXM600, wird nun eine Verbindung mit dem Handgerät im DMO (Direktmodus) via MXM600 in das Funknetz ermöglicht.

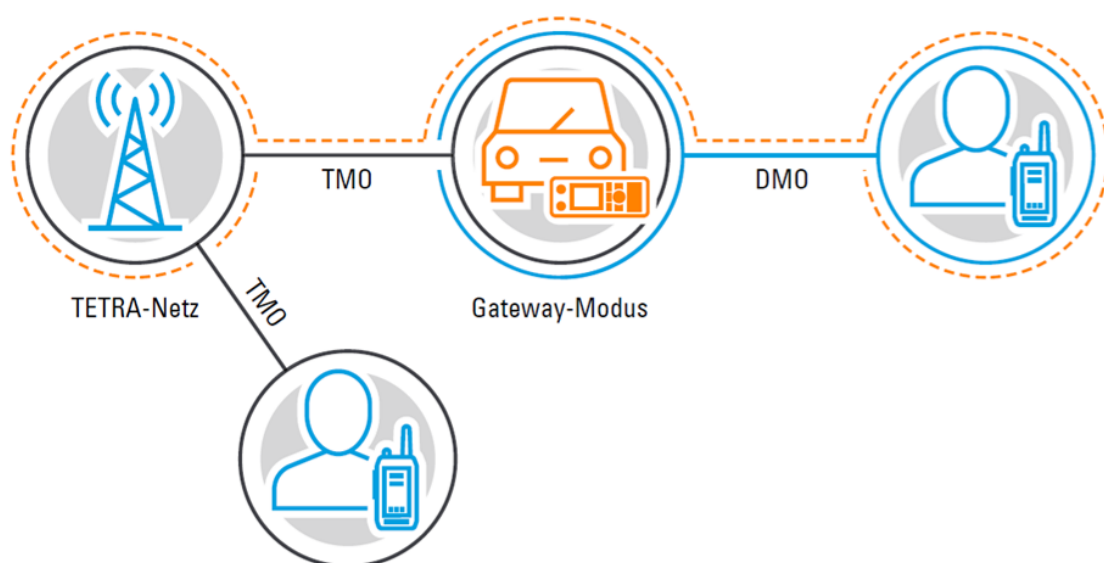

TETRA-FAHRZEUGFUNKGERÄTE

SERIE MXM600

Spezifikation / technische Daten:

TETRA SERVICES	
RF	
Frequency bands	350 - 470 MHz
Transmitter RF power	10 W (class 2) and 3 W (class 3)
Adaptive RF power control	Yes: starting at 15 dBm; finishing at 40 dBm
Receiver class	A and B
Receiver static sensitivity	-116 dBm minimum, -118 dBm typical (ETSI 300-392-2)
Receiver dynamic sensitivity	-107 dBm minimum, -109 dBm typical (ETSI 300-392-2)
FCC emissions designator	22K0D1D, 22K0D1E, 22K0D1W
VOICE	
Full duplex	TMO: private, PABX, PSTN, MS-ISDN, emergency
Half duplex	TMO: private, group, emergency
	DMO: private, group, emergency
Emergency call (user customisable)	Tactical: emergency group call to attached talkgroup
	Non-tactical: emergency group call to dedicated talkgroup
	Individual: emergency call to pre-defined party (half/full duplex)
	Hot mic: configurable timers for automatic open mic (talk without PTT)
	Smart emergency: TMO to DMO and DMO to TMO automatic switching options
	Location: location (GNSS) is sent with emergency
	Target address: sent to individual or group address (selected or dedicated)
	Alarm (status message): Emergency Status (or other predefined status)
DGNA	Up to 10,000 groups
Other voice functions	Phonebook: 1000 persons, 6 numbers per each, 2000 maximum entry
	<ul style="list-style-type: none"> Scanning: 40 lists of 20 talkgroups, monitoring 20 groups at the same time (selected talkgroup and passive monitoring) Announcement talkgroup: 1 primary talkgroup that can monitor other talkgroups
DATA	
Short Data	Status: <ul style="list-style-type: none"> • 400 entries, send via One-Touch Button (OTB) or via menu • TMO and DMO
	SDS: <ul style="list-style-type: none"> • Concatenation up to 1000 characters • TMO and DMO
	Target address: sent to individual or group address (selected or dedicated)
	SDS messages can be sent and received during a voice call
Packet Data	Call out (simple, full, E2EE)
	Multi-slot Packet Data: data transmission with up to 4 slots supporting up to 28.8 kbit/s in total
PEI (Peripheral Equipment Interface)	<ul style="list-style-type: none"> • TNP1: Simultaneous operation of Packet Data and Short Data Services over a common Peripheral Equipment Interface (PEI) • AT Commands: full set of ETSI and Enhanced AT Commands • AT multiplexer: 4 virtual physical port (simultaneous PD, SDS, AT Commands and Air Tracer Sessions)
WAP	WAP 1.2.x and WAP 2.0 compatibility for UDP/IP stack

TETRA-FAHRZEUGFUNKGERÄTE

SERIE MXM600

Spezifikation / technische Daten:

TETRA SERVICES (CONTINUED)	
DMO / TMO GATEWAY SERVICES	
	Group voice calls from DMO to TMO
	Group voice calls from TMO to DMO
	Emergency group call from DMO to TMO
	Emergency group call from TMO to DMO
DMO / TMO gateway mode	Call pre-emption (in either direction)
	SDS messaging through the gateway from DMO to TMO or TMO to DMO
	Configurable routing of SDS messages to console or PEI
	Point to point calls and SDS messages whilst operating as a gateway
DMO REPEATER SERVICES	
	Repeats DMO voice calls on selected talkgroup
	Repeats SDS and Status messaging on selected talkgroup
	ETSI type 1A DMO repeater for channel efficient operation
DMO repeater mode	Transmission of Repeater Presence Signal
	Priority call, Emergency call (Preemptive Priority call)
	End-to-End Encryption (E2EE) DMO traffic
	Monitoring of and participation in calls whilst in Repeater mode
	Configurable repeater power levels
CONNECTIVITY	
WI-FI	
IEEE standards supported	802.11 a, b, g, n, ac
Wi-Fi bands	2.4 GHz and 5 GHz
Authentication and encryption	<ul style="list-style-type: none"> • WPA • WPA2 • WPA2 Enterprise (EAP-TLS)
Security	TLS 1.2 (OTAP application)
BLUETOOTH	
Bluetooth versions supported	Bluetooth 5.2, 5.1, 5.0, 4.2, 4.1, 4.0, and 2.1 + EDR
Bluetooth range	Bluetooth power: Class 1 Line of sight range is up to 90 m (accessory dependent)
Bluetooth security	<ul style="list-style-type: none"> • With Secure Connections (used in security mode 1, level 4 as recommended by NIST¹) • Supports Advanced Encryption Standard (AES) algorithm, with 128 bit key length • Also uses an algorithm for Bluetooth key generation and key authentication
Bluetooth audio profiles	<ul style="list-style-type: none"> • Headset Profile (HSP) • Serial Port Profile (SPP) • Generic Access Profile (GAP) • Generic Attributes Profile (GATT)
SECURITY	
Air Interface Encryption Authentication	Infrastructure initiated and made mutual by terminal
Air Interface Encryption algorithm options	<ul style="list-style-type: none"> • TEA1 • TEA2 • TEA3 (Hardware ready for TEA5, TEA6, TEA7 and dual encryption)
Air Interface Encryption Protocols - security classes	<ul style="list-style-type: none"> • Class 1 (Clear) • Class 2 (SCK) • Class 3 (DCK/CCK, OTAR-CCK, OTAR-SCK) • Class 3G (GCK, OTAR-GCK)
End-to-End Encryption (E2EE) options	<ul style="list-style-type: none"> • AES128 or AES256 for voice and short data with OTAK supported through an optional Hardware Security Module (HSM) • Encrypted SDS messaging to the Short Data Router (SDR) via the Short Data Encryption Gateway (SDEG) • Internal TETRA SIM card: via integrated card slot • External SIM card reader connected through a rear accessory connector or a Dual Remote Transceiver's RJ50 SIM port
User access control	PIN/PUK code access <ul style="list-style-type: none"> • Selection for Radio User Assignment (RUA) / Radio User Identity (RUI) Operation • RUA / RUI allows a radio user to authenticate and have access to only those radio capabilities defined in pre-installed service profile. • Setup for forwarding of calls and SDS from permanent radio to the currently assigned radio. • Users who are logged on to a radio different from their permanent radio can still be reached (called, send SDS) at permanent radio number (P-ISSI). • RUA / RUI are not supported when E2EE is enabled.
Other security features	Temporary disable (stun) Permanent disable (either ETSI standard or customer restorable) Packet data user authentication
LOCATION SERVICES	
SATELLITE / OUTDOOR NAVIGATION SERVICE	
Constellations supported	GPS plus one of: Galileo, GLONASS, and BDS (BeiDou), Satellite-Based Augmentation Systems (SBAS) including QZSS
Antenna	External antenna, supports active antenna (5 V, 25 mA supply)
Simultaneous satellites	12
GNSS acquisition sensitivity	GPS: -145 dBm (guaranteed); -146 dBm (typical)
GNSS tracking sensitivity	GPS: -163 dBm (guaranteed); -164 dBm (typical) BDS (BeiDou): -155 dBm (guaranteed); -156 dBm (typical) GLONASS: -157 dBm (guaranteed); -160 dBm (typical) Galileo: -155 dBm (guaranteed); -157 dBm (typical)
Horizontal accuracy, 2D	1.2m (95% probable, -130 dBm, >15 SVs Galileo and GPS)
Protocols	<ul style="list-style-type: none"> • ETSI LIP (Short and Long) • Motorola Solutions LRRP
TTFF cold start	<60 sec (95% probable at -130 dBm)
TTFF hot start	<10 sec (95% probable at -130 dBm)

¹ <https://csrc.nist.gov/publications/detail/sp/800-121/rev-2/final>

TETRA-FAHRZEUGFUNKGERÄTE

SERIE MXM600

Spezifikation / technische Daten:

USER INTERFACES

Display	<ul style="list-style-type: none"> IP54 RECH and IP67 RECH: 2.8" (43.2 x 57.6 mm), VGA - 640 x 480 pixel, 65K colours TSCH: 2.0" (30.6 x 40.8 mm) TFT colour transfective display, 240 x 320 black pixels on white background, 65K colours 	Contacts management	Rapid search to find the contact easily		
	Variable backlight, user configurable	Contacts	<ul style="list-style-type: none"> Up to 1000 contacts Up to 6 numbers per contact, maximum of 2000 numbers in total 		
	Font size: standard and zoom mode (90 pixels, 4.5 mm high) characters	Dialling methods	One-Touch Buttons (OTB), from the favourite folders, from the address book, from the recent calls list, direct dialling, from the embedded numbers in Short Data Service messages, speed dialling, talkgroup dialling by index		
	Multiple display languages, user selectable	Call alert	Short alert tone (configurable) for group incoming calls		
	Time display	Ring tones	Configurable via CPS / ITM		
	Configurable screen saver: GIF image / text	Message manager	Distinct folders for each message type for flexible message management		
	TSCH has rotating display: <ul style="list-style-type: none"> When off-hook, portrait orientation When on-hook, fixed portrait, clockwise rotation, counter clockwise rotation When 2 x TSCHs, both have portrait orientation 	Text message list	<ul style="list-style-type: none"> 100 short and 20 long messages (up to 1000 characters) for outbound 100 short and 10 long messages (up to 1000 characters) for inbound 		
	Status LED	Tri-colour status LED on control heads and transceiver	Status list	400 predefined messages assignable to One-Touch Buttons (OTB)	
	Tones	Configurable notification tones	Covert mode	Yes	
	Controls	<ul style="list-style-type: none"> Rotary, talkgroup (when pressed) and volume change dual function with lock option 4-way navigation key, menu and soft keys Emergency button with backlight 3 programmable function keys (plus 10 programmable numeric keys) User configurable shortcuts to menus and common features using "One-Touch-Button" (OTB) feature 	Dual control head	Configuration options: <ul style="list-style-type: none"> 1 IP54 RECH and 1 TSCH 1 IP54 RECH and 1 IP67 RECH 1 IP67 RECH and 1 TSCH 2 x IP54 RECH 2 x IP67 RECH 2 x TSCH Both displays are active with the following configurations: <ul style="list-style-type: none"> 2 x IP54 RECH 2 x IP67 RECH 2 x TSCH 1 x IP54 RECH and 1 x IP67 RECH Single display is active with either of these configurations: <ul style="list-style-type: none"> IP54 RECH and TSCH IP67 RECH and TSCH 	
International keypad options ²		Keypad	Multi radio control	<ul style="list-style-type: none"> A single IP54 RECH or IP67 RECH or TSCH controls 2 transceivers Display follows PTT 	
Back-lit character keypad with keypad lock option					
3 programmable function keys (plus 10 programmable numeric keys)	Text entry	Predictive keypad text entry	Third party control head	<ul style="list-style-type: none"> Third party developed control head solution (physical or virtual) with the MXM600 transceiver Motorola Solutions Remote Display Control (RDC) protocol is used for the solution (through Application Developer Program) Optional use with IP54 RECH or IP67 RECH or TSCH in the dual control head configuration 	
Menu	Customisable menu	Menu shortcuts	Automated control head detection ³	Yes	
Talkgroup management	User friendly, flexible, fast and efficient interface	Talkgroups	Auto control head software update ³	Yes	
<ul style="list-style-type: none"> Dual layer folder structure (folder/subfolder) TMO folders: up to 500, TMO talkgroups: up to 10000 DMO folders: up to 128, DMO talkgroups: up to 2000 4000 TMO Entries (up to 2048 entries in one folder) 	Favourite talkgroup folders	Up to 3 folders (128 groups each, 384 groups in total)			
Scan lists	40 lists of up to 20 groups	Country/Network code list	100		

TETRA-FAHRZEUGFUNKGERÄTE

SERIE MXM600

Spezifikation / technische Daten:

DEVICE MANAGEMENT SOLUTIONS

Customer Programming Software (CPS) Requires CPS version 8.2 or newer

Integrated Terminal Management (iTM) Requires iTM version 8.2 or newer

Over-The-Air Updates (via iTM) • Supports Over-The-Air-Programming (OTAP) for configuration (codeplug) and Over-The-Air Updates (OTA Updates) for firmware via Wi-Fi.

Wired Updates (via CPS or iTM) • Supports programming for configuration (codeplug) and updating radio firmware
• Via a transceiver's 26-pin rear connector
• Via a control head GCAI MMP connector

RECOMMENDED SERVICES

Services for TETRA radios Visit motorolasolutions.com/mxm600 for more information

ENVIRONMENTAL SPECIFICATIONS

Operating temperature^d -30 to +70 °C

Storage temperature -40 to +85 °C

Humidity (condensation and high), temperature change, low and high temperature ETSI 300 019-1-5 class 5.2

Shock (bumps and shock), drop (free fall, drop and topple) and vibration (random and sine) ETSI 300 019-1-5 class 5M3

Dust and water Ingress Protection • IP54 for all transceiver models (even with cables connected)
• IP54 for IP54 RECH
• IP55 for TSCH
• IP67 for IP67 RECH

REGULATORY COMPLIANCE

Radio RED 2014/53/EU directive

Environmental EN 50155 (IEC 60571 ED. 3.0)

Automotive E-mark, ECE Regulation No.10 for Electrical/Electronic-Subassembly

Rail Certification EMC EN 50121-3-2 (IEC 62236-3-2 Ed.2.0)

US MILITARY STANDARD MATRIX

	MIL-STD 810 C		MIL-STD 810 D		MIL-STD 810 E		MIL-STD 810 F		MIL-STD 810 G		MIL-STD 810 H	
Applicable MIL-STD	Method	Proc/Cat	Method	Proc/Cat	Method	Proc/Cat	Method	Proc/Cat	Method	Proc/Cat	Method	Proc/Cat
Low pressure	500.1	I	500.2	II	500.3	II	500.4	II	500.6	II	500.6	II
High temperature	501.1	I, II	501.2	I/A1, II/A1	501.3	I/A1, II/A1	501.4	I/Hot, II/Hot	501.6	I/A1, II/A1	501.7	I/A1, II/A1
Low temperature	502.1	I	502.2	I, II	502.3	I, II	502.4	I, II	502.6	I, II	502.7	I, II
Temperature shock	503.1	I	503.2	A1/C3	503.3	A1/C3	503.4	I	503.6	I-C	503.7	I-C
Solar radiation	505.1	II	505.2	I/A1	505.3	I/A1	505.4	I/A1	505.6	I/A1	505.7	I/A1
Rain	506.1	I, II	506.2	I, II	506.3	I, II	506.4	I, III	506.6	I, III	506.6	I, III
Humidity	507.1	II	507.2	II	507.3	II	507.4	Yes	507.6	II/ Aggravated	507.6	II/ Aggravated
Salt fog	509.1	I	509.2	I	509.3	I	509.4	Yes	509.6	Yes	509.7	Yes
Blowing dust and sand	510.1	I	510.2	I, II	510.3	I, II	510.4	I, II	510.6	I, II	510.7	I, II
Vibration	514.2	VIII/CatF, XI	514.3	I/Cat10, II/Cat3	514.4	I/Cat10, II/Cat3	514.5	I/Cat24, II/Cat5	514.7	I/Cat24, II/Cat5	514.8	I/Cat24, II/Cat5
Shock	516.2	I,III, V	516.3	I, V, VI	516.4	I, V, VI	516.5	I, V, VI	516.7	I, V, VI	516.8	I, V, VI



MOTOROLA SOLUTIONS

PLATINUM RESELLER

AMV Funktechnik Handels GmbH

Oskar Schulze Straße 7

28832 Achim

Telefon 0421 4899760 Telefax 0421 4899 76 260

Email Kontakte@AMV-Funktechnik.de

www.AMV-Funktechnik.de

Version 01.02.2026 / MXM600-2026

Technische Änderungen vorbehalten

